

Practice Assessment

Utilities Engineering Technician

Please write clearly in block capitals below	
Company name	
First name (s)	
Last name (s)	
Date of birth	
Apprentice signature	
Date of knowledge test	

Level: 3
Standard: Utilities Engineering Technician
Pathway: Mechanical

Duration: 1 hour

Materials

For this paper you must have:

- Pens
- Scientific calculator (non-programmable)

Instructions

- Use black ink or black ball-point pen
- Fill in the boxes at the top of this page
- Answer **all** questions
- There are questions, possible answers as well as a column for you to mark your answer
- Mark your answer with an against the possible answer you think is correct- if you wish to change your answer please put a line through and re-select with another

- Only one answer per question allowed. Answers which do not follow the rules of selection will be disallowed. This may impact on the grade awarded
- Do all rough work in this answer book

Below is a Sample:

London is the capital of....

Example Question		
London is the capital of...		
Possible answers		Answer
a)	Wales	X
b)	Scotland	
c)	Northern Ireland	
d)	England	X

Information

- There are 40 questions
- All questions should be attempted
- The pass mark is 28

Advice

- Do not spend too long on one question
- Read all questions thoroughly before starting your examination
- Mobile phones and watches must not be taken into the examination room. The examination must be conducted under examination conditions
- Cheating: you will be asked to leave the examination room and will be classified an automatic failure and referred to your employer

THIS PAPER MUST NOT BE COPIED OR CIRCULATED WITHOUT THE WRITTEN PERMISSION OF THE EUIAS

Do not turn over the page or commence the knowledge test until the invigilator instructs you to



Question 1	
What type of safety sign is shown below?	
Possible answers	Answer
a) Mandatory	
b) Warning	
c) Prohibition	
d) Emergency	

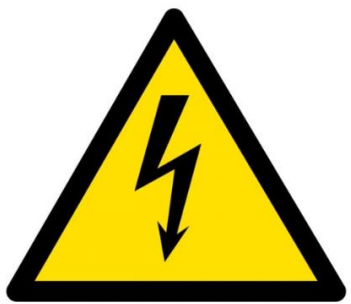

Question 2	
State ONE purpose of completing a Control of Substances Hazardous to Health Regulations (COSHH) assessment in the workplace.	
Possible answers	Answer
a) To decide how heavy chemical containers are	
b) To collect information about employees' health	
c) To decide how often to check chemical stock levels for re-ordering	
d) To identify the potential for exposure to harmful material	

Question 3	
What is the first action that should be taken when assessing a potentially hazardous substance?	
Possible answers	Answer
a) Provide appropriate PPE (Personal Protective Equipment)	
b) Check the MSDS (Material Safety Data Sheet)	
c) Check that there is space to store it safely	
d) Conduct a risk assessment	

Question 4

According to Health, Safety and Environment (HSE) guidelines which ONE of the following controls is the least effective?

Possible answers		Answer
a)	Elimination	
b)	Engineering	
c)	PPE	
d)	Substitution	

Question 5

Which ONE of the following activities must be completed before working in a confined space?

Possible answers		Answer
a)	Ensure there is a safe system for working inside the space	
b)	Check the worker has the right qualification	
c)	Modify the area so entry is not necessary	
d)	Provide access and egress routes	

Question 6

Which ONE of the following is commonly classed as safety-critical?

Possible answers		Answer
a)	Fuse	
b)	Control valve	
c)	Steam trap	
d)	Drain valve	

Question 7		
Two technicians are working on the same piece of equipment which is isolated using a padlock.		
What safe isolation practice should be used?		
Possible answers		Answer
a)	Give each technician a key to the padlock	
b)	Use a multi padlock isolation tool	
c)	Leave the key tied to the padlock	
d)	Apply a long-term isolation	

Question 8		
Which ONE of the following regulations provide guidance on the use of handheld tools?		
Possible answers		Answer
a)	Control of Substances Hazardous to Health (COSHH)	
b)	Provision and Use of Work Equipment Regulations 1998 (PUWER)	
c)	Lifting Operations and Lifting Equipment Regulations 1998 (LOLER)	
d)	Control of Major Accident Hazards Regulations 2015 (COMAH)	

Question 9		
In accordance with Health and Safety Executive (HSE) guidelines, which ONE of the following apply isolations?		
Possible answers		Answer
a)	Experienced people	
b)	Skilled people	
c)	Lead technicians	
d)	Authorised people	

Question 10		
In accordance with Health and Safety Executive (HSE) regulations, how would you know if a substance was regarded as hazardous?		
Possible answers		Answer
a)	The substance will give off a strong odour	
b)	The substance will have a label identifying the hazard	
c)	The substance will be contained in a glass receptacle	
d)	The substance will be in a red container	

Question 11		
What type of information is provided on the coloured tag on a piece of rigging equipment?		
Possible answers		Answer
a)	Certification period	
b)	Safe working load	
c)	Maximum working load	
d)	Safe to use	

Question 12		
What type of document should be fixed to a scaffold before use?		
Possible answers		Answer
a)	Risk assessment	
b)	Safety certificate	
c)	Permit to work	
d)	Approved Scafftag	

Question 13		
Assuming an emergency shower is close by, what should a technician do if they come into contact with hazardous substances whilst wearing a protective suit?		
Possible answers		Answer
a)	Remove all clothing and douse down under the shower	
b)	Stand under the shower immediately and douse down under the shower	
c)	Complete the task and then douse down under the shower	
d)	Stop work and immediately report to the first aid room	

Question 14		
A gas test has been completed within a confined space. Which oxygen reading would allow safe entry into the confined space?		
Possible answers		Answer
a)	19.5% - 23.5%	
b)	14% - 19%	
c)	6% - 14%	
d)	< 6%	

Question 15		
An operative is asked to carry out a task that will create dust. What will they need to do?		
Possible answers		Answer
a)	Dust is not a hazardous substance, so no safety measures are required	
b)	Wait until the wind is strong so it will blow the dust away	
c)	Wear the PPE identified on the permit or risk assessment	
d)	Only work for short periods and take regular breaks	

Question 16		
When working in these locations which one does NOT require a Confined Space Entry Permit?		
Possible answers		Answer
a)	Refrigeration Unit	
b)	Trench	
c)	Vessel	
d)	Ceiling Void	

Question 17		
Which ONE of the following must be tested before entering a confined space?		
Possible answers		Answer
a)	Number of people wanting access	
b)	Oxygen content	
c)	Size of area	
d)	Noise levels	

Question 18		
What is the correct order of working at height control measures?		
Possible answers		Answer
a)	<ol style="list-style-type: none"> 1. Fall prevention 2. personal fall protection 3. avoid work at height 4. collective fall protection 	
b)	<ol style="list-style-type: none"> 1. Avoid work at height 2. fall prevention 3. collective fall protection 4. personal fall protection 	
c)	<ol style="list-style-type: none"> 1. Avoid work at height 2. collective fall protection 3. fall prevention 4. personal fall protection 	
d)	<ol style="list-style-type: none"> 1. Personal fall protection 2. collective fall protection 3. fall prevention 4. avoid work at height 	

Question 19		
How regularly should electrical safety equipment be inspected?		
Possible answers		Answer
a)	Daily	
b)	Weekly	
c)	Monthly	
d)	Prior to use	

Question 20		
Which ONE of the following manual handling statements is true?		
Possible answers		Answer
a)	Correct manual handling prevents all accidents	
b)	Correct manual handling prevents damage to equipment	
c)	Correct manual handling should only be applied in the workplace	
d)	Correct manual handling reduces the risk of human injury	

Question 21		
In terms of psi (pound/square inch), what is 1 bar is equivalent to?		
Possible answers		Answer
a)	1.47 psi	
b)	14.7 psi	
c)	17.4 psi	
d)	147 psi	

Question 22		
What is the surface area of the cube in the image?		
The length of each side is 1 inch.		
Possible answers		Answer
a)	36 inches ²	
b)	6 inches ²	
c)	4 inches ²	
d)	1 inch ²	

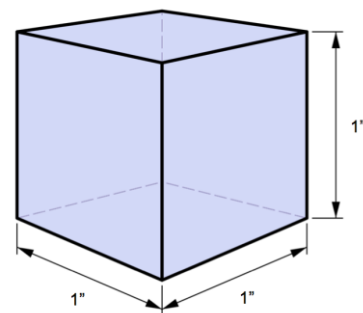

Question 23		
What is the SI (International System of Units) name for force?		
Possible answers		Answer
a)	Hertz	
b)	PSI	
c)	Watts	
d)	Newton	

Question 24		
When seen on a flange, what does 150lb refer to?		
Possible answers		Answer
a)	Weight	
b)	Pressure rating	
c)	Cost code	
d)	Size	

Question 25		
Which ONE of the following definitions best fits the terminology 'specification'?		
Possible answers		Answer
a)	The capacity to withstand continuous force	
b)	The standard when measured against another object of similar design	
c)	A detailed description of the design and materials of an object	
d)	The specified point beyond which certification is invalid	

Question 26

What does the symbol below represent when seen on a British Standard convention drawing?



Possible answers		Answer
a)	Electrical signal	
b)	Instrument signal	
c)	Hydraulic line	
d)	Pneumatic line	

Question 27

Which of the following is **NOT** one of the elements needed to start a fire?

Possible answers		Answer
a)	CO ₂ (Carbon Dioxide)	
b)	Fuel	
c)	Heat	
d)	Oxygen	

Question 28

Which type of maintenance schedule is more likely to lessen the likelihood of plant or equipment failure

Possible answers		Answer
a)	Reactive maintenance	
b)	Risk based maintenance	
c)	Condition based maintenance	
d)	Preventative maintenance	

Question 29		
Looking at the image provided and taking into consideration risk, which task is low probability and low in impact?		
Possible answers	Answer	
a) A	X	
b) B		
c) C		
d) D		

A

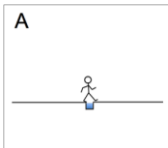

B

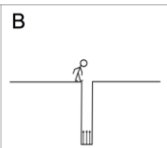

C

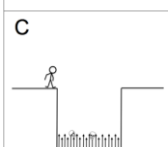

D

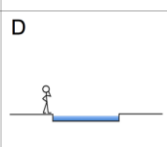

Question 30		
What would be a typical sign that a filter was starting to become blocked?		
Possible answers	Answer	
a) Increase in differential pressure		
b) Static differential pressure		
c) Decrease in differential pressure		
d) Zero differential pressure		

Question 31		
What is the metric SI (International System of Units) unit for torque?		
Possible answers	Answer	
a) Mn		
b) Nm		
c) Tq		
d) N		

Question 32

What type of maintenance is Root cause analysis?

Possible answers		Answer
a)	Preventative	
b)	Reflective	
c)	Planned	
d)	Reactive	

Question 33

Refer to the diagram below.

Calculate the difference between the flow rates of pump 1 and pump 4.

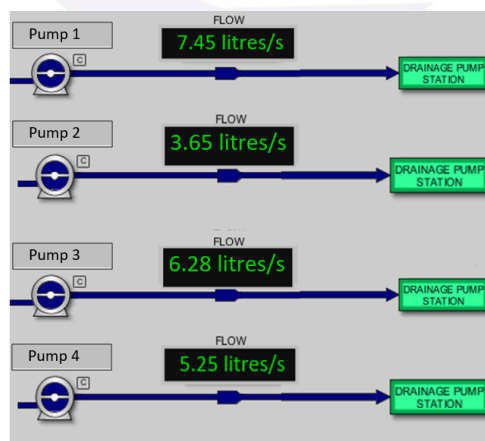

Possible answers		Answer
a)	2.05 litres per second	
b)	2.20 litres per second	
c)	2.25 litres per second	
d)	3.25 litres per second	

Question 34

Refer to the display below.

Identify the average hours run time on the pump sets.

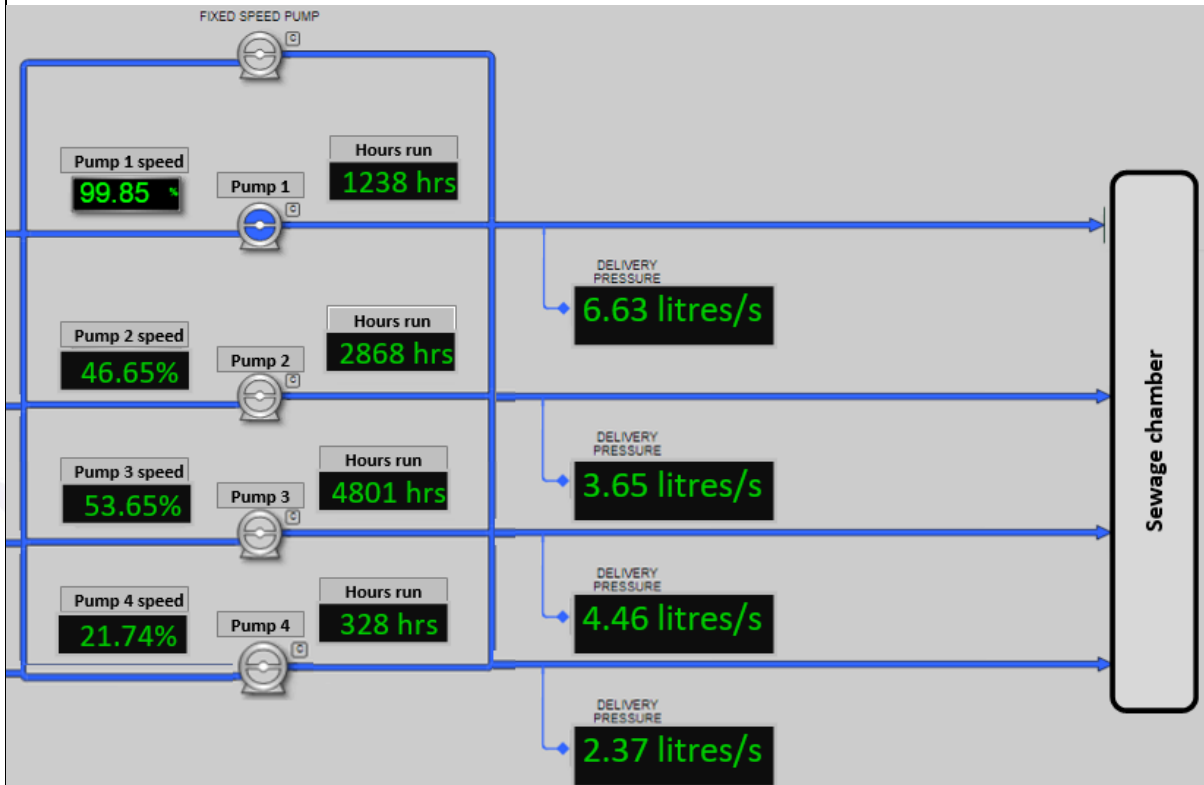

Possible answers		Answer
a)	3196.00 hours	
b)	2308.80 hours	
c)	55.47 hours	
d)	4.27 hours	

Question 35

Refer to the image below.

Which ONE of the following instruments would display this information?

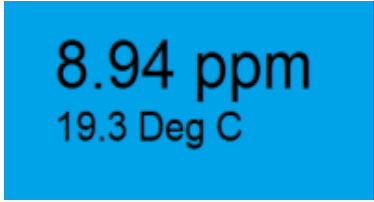
Possible answers		Answer
a)	Dissolved oxygen analyser	
b)	Temperature transmitter	
c)	Human Machine Interface	
d)	pH probe	

Question 36

Refer to the trend analysis snapshot below of a pumping station.

On what day did the maximum flow rate occur?

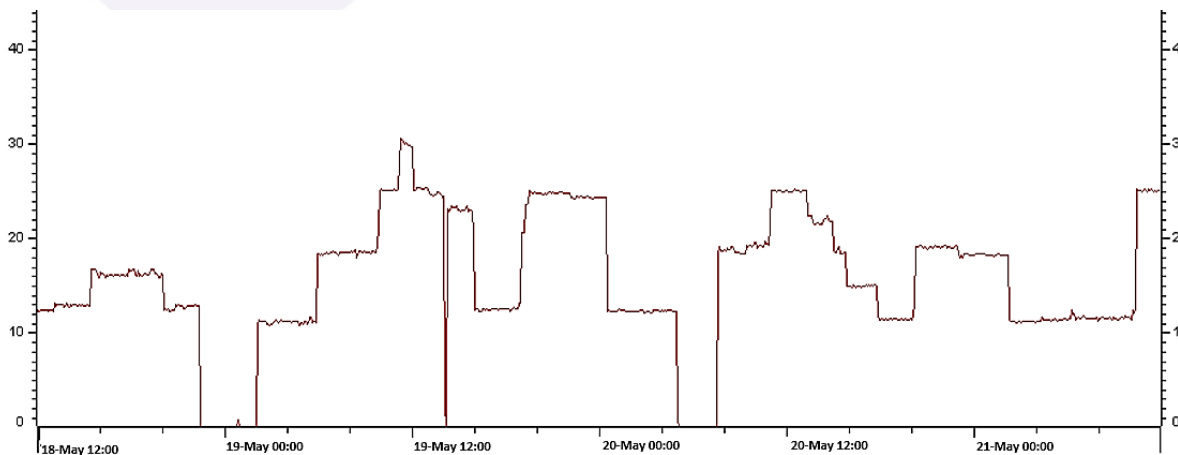

Possible answers		Answer
a)	18 May	
b)	19 May	
c)	20 May	
d)	21 May	

Question 37

Refer to the image below.

What measurement is the reading displaying?

Possible answers		Answer
a)	Signal velocity	
b)	Viscosity of a liquid	
c)	Capacitance Probe (RF)	
d)	Turbidity	

1.84 NTU

Question 38

Refer to the display below.

If 1.0 bar of pressure equals approximately 10.1972 mH₂O, what is the current level in mH₂O of bore hole 1

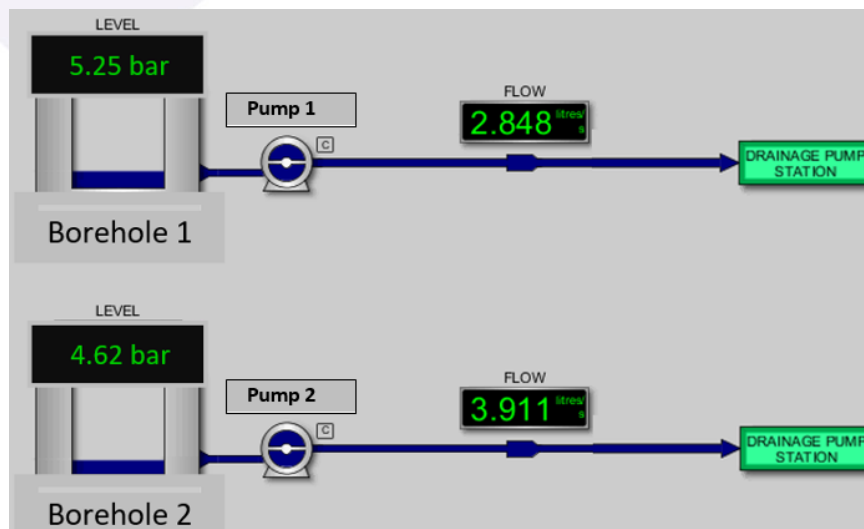

Possible answers		Answer
a)	29.04 mH ₂ O	
b)	39.9 mH ₂ O	
c)	47.1 mH ₂ O	
d)	53.5 mH ₂ O	

Question 39

Refer to the extract from a SCADA display.

Which ONE of the following figures is the flowrate from the brine tank to the Recovery?

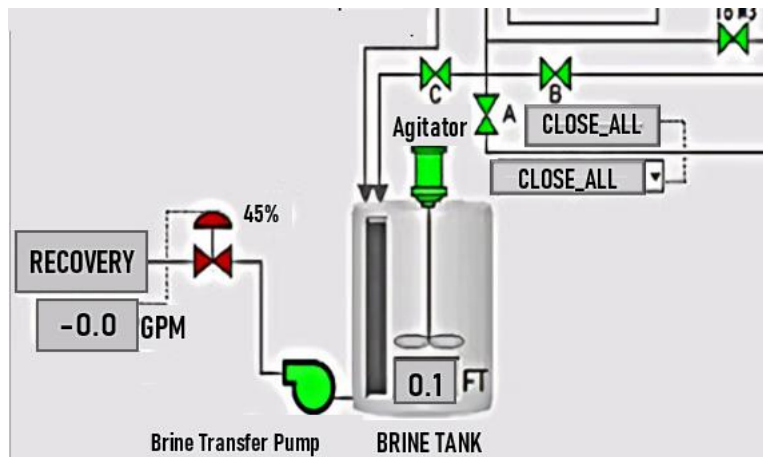

Possible answers

Answer

a)	-0.0 Gallons Per Minute	
b)	The information is not in the display	
c)	0.1 FT	
d)	45%	

Question 40

Refer to the extract from a SCADA display. There is no flow rate being measured from the mill tank to the reactor.

What could prevent the water flow reaching the reactor?

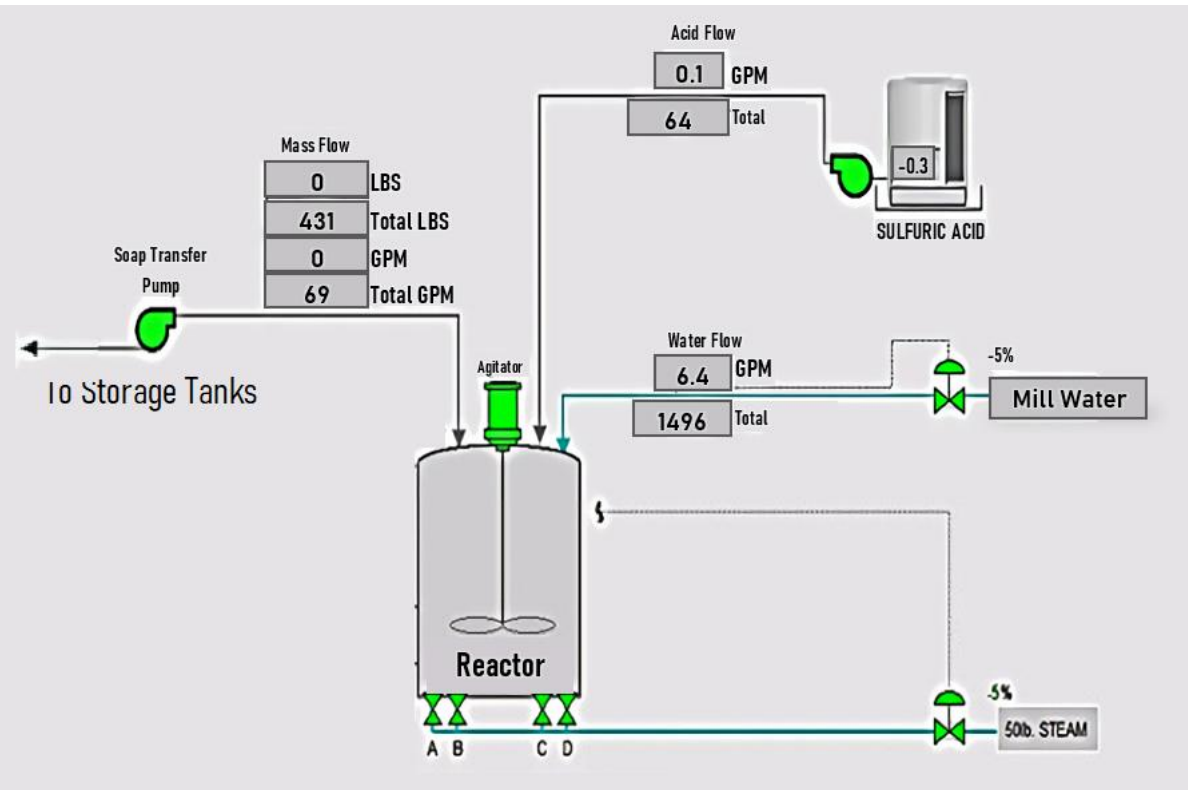

Possible answers		Answer
a)	High levels in the storage tank	
b)	Open pneumatic valve	
c)	Blockage from the West Storage	
d)	Closed pneumatic valve	

End of Practice Knowledge Assessment

Practice Knowledge Assessment

Answer scheme

Question	Answer	Question	Answer	Question	Answer
1	B	15	C	29	A
2	D	16	D	30	A
3	B	17	B	31	B
4	C	18	B	32	D
5	A	19	D	33	B
6	A	20	D	34	B
7	B	21	B	35	A
8	B	22	B	36	B
9	D	23	D	37	D
10	B	24	B	38	D
11	A	25	C	39	A
12	D	26	D	40	D
13	B	27	A		
14	A	28	D		